

Draft!

To be published in the proceedings of the "VIIIth European Symposium
on Materials and Fluid Sciences in Space", April 92, Brussels

STUDY OF VAPOR BUBBLE GROWTH IN A SUPERSATURATED LIQUID

J. Straub¹, J. Winter¹, G. Picker¹, H. Merte², A. Kono³

¹ LATTUM, TU München, Arcisstr. 21, 8000 München 2, Germany

² University of Michigan, Ann Arbor, USA

³ JGC Corporation, Yokohama, Japan

Abstract

An experiment called: "Nucleation, bubble growth, interfacial phenomena and evaporation / condensation kinetics" is foreseen for the BDPU on IML 2. We performed first experiments in the laboratory and also during parabolic flights, using our laboratory set-up. The intention was to get first scientific results and to reduce the technological uncertainties in the development of the BDPU test container.

The process starts at a high system pressure to deactivate the nuclei at the walls of a test cell. The pressure is reduced below saturation by a quasi isothermal expansion. The bubble growth is initiated by a short heating pulse of a thermistor in the liquid. The volume of the growing bubble is compensated by a pressure control system. After this cycle the pressure is increased again and recondensation is observed.

The test of the experimental set-up was successful. Experiments were performed in the laboratory as well as under microgravity conditions during parabolic flights at the 14th ESA campaign. Only small vapor bubbles can be observed under normal gravity, under reduced gravity however, vapor bubbles up to 1 cm in diameter can be produced. Nevertheless the system is very sensitive to gravity disturbances.

We obtained first results about bubble growth in a supersaturated liquid. We gathered also technological data, which are important for the development of the BDPU test container.

In future parabolic flight experiments and also in the BDPU, the evaporation and condensation kinetics at the liquid vapour interface will be studied by measurements of the temperature field around the bubble using optical interferometry.

Keywords: nucleation, bubble growth, interfacial phenomena, evaporation and condensation kinetics;

1 Introduction

An experiment for the investigation of nucleation, bubble growth, interfacial phenomena and evaporation/condensation kinetics is planned for the BDPU on IML 2. The main aim of the experiment is the investigation of the evaporation and condensation kinetics at the interphase of vapor bubbles in a homogeneous supersaturated liquid under well defined conditions. Measured values for the kinetic evaporation and condensation coefficients for water, for example, vary over some decades.

To determine the temperature field around a growing vapor bubble, at the interphase on the liquid side, optical interferometry will be used.

The vapor bubble to be investigated is initiated by a short heating pulse of a spot heater (i.e. thermistor). Following this, the vapor bubble will grow in the supersaturated liquid undisturbed by buoyancy or by buoyancy induced convection and undisturbed by Marangoni Convection, due the homogeneous temperature field at the bubble surface.

The first experiments were performed with a laboratory set-up during parabolic flights supported by ESA in September and December 1993. The primary objectives of these experiments were threefold:

1. To demonstrate the feasibility of the experiment proposed and to optimize the thermodynamic process;
2. To obtain technological data for the development and design of the BDPU test container;
3. To obtain early scientific results to maximize the scientific return from the Spaceiab experiment being planned.

These experiments will be described in the following, along with the scientific background.

2 Scientific Objectives

The thermodynamic process of the experiment will be described first for a better understanding of the scientific objectives, to be followed by the development of the scientific objectives.

2.1 The Thermodynamic Process

The bubble growth and collapse (evaporation and condensation), referred in general as the bubble dynamics, is studied in a homogeneous supersaturated liquid under well defined conditions. The isothermal supersaturated liquid is produced by reducing the total pressure from the initially compressed liquid state to a pressure below the saturation pressure corresponding to its temperature. Following the bubble formation and growth, bubble collapse is induced by increasing the pressure, resulting in condensation of the vapor. Microgravity conditions are necessary in order that larger bubbles can be produced and optically observed, bubbles which will not be removed from the field of view by buoyancy.

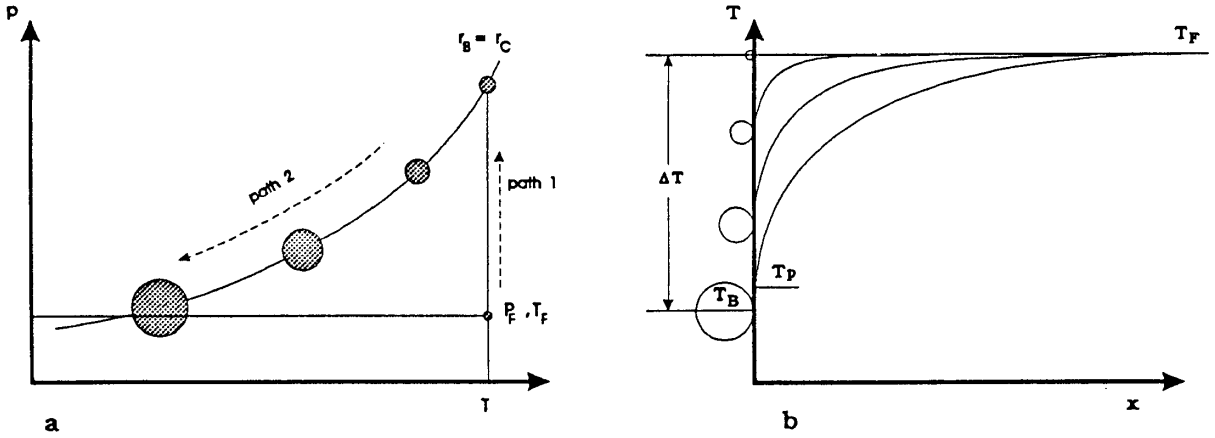

Figure 2: a) Bubble growth on the $p - T$ phase diagram; b) Temperature field around the bubble

- bubble nucleation,
- bubble growth,
- bubble condensation.

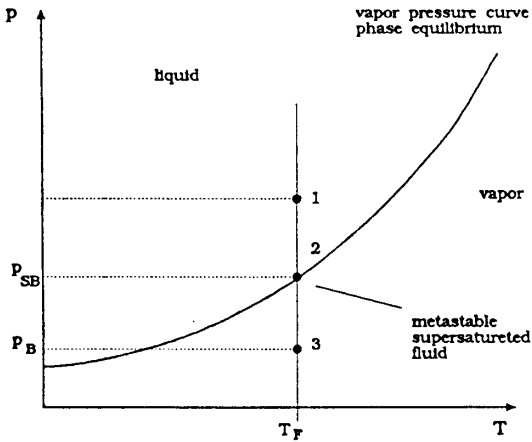

Figure 1: The proposed process shown on a $p - T$ phase diagram

The process is shown in the phase diagram of a representative fluid in Fig. 1. The fluid is heated to and maintained at a uniform temperature. By increasing the pressure above saturation (state 1) to p_1 , the vapor nuclei, which are found on the surfaces of the container and solid components, will be inactivated down to a distinct size corresponding to $r = 2\sigma/\Delta p$, where σ is the surface tension, Δp is the pressure difference between the system pressure p_1 and the saturation pressure p_{SB} , and r is the radius of the smallest nucleus to be deactivated.

Following this, the system pressure will be reduced to various levels of pressure p_3 below saturation. The liquid in state 3 is supersaturated and the bubble can be activated. After the desired bubble growth period, the pressure is increased again to p_1 to produce the desired bubble condensation process.

2.2 Scientific Background

The experiment can be divided into three phases:

Bubble Nucleation

During this experiment heterogeneous nucleation will be observed. Homogeneous nucleation cannot be expected to take place, in most cases, except at high pressures and in the vicinity of the critical point. By deactivating the nuclei to a certain extent, specified by the pressure level imposed during the initial pressurization, studies of heterogeneous nucleation and nuclei activation become possible, since well defined boundary conditions can be established and the temperature field will not be disturbed by convection.

Bubble Growth

The process of the bubble growth is shown in Fig 2.

Following nucleation the thermodynamic state within the bubble will be close to saturation (path 1). Thereafter the bubble will undergo further growth in the supersaturated liquid, due to the potential difference relative to the surrounding liquid (path 2). The result is an increasing temperature difference between the bubble and the bulk liquid (Fig. 2b). This temperature difference increases with increasing r_B and provides the necessary energy transport to the bubble as:

$$\Delta T = T_F - T_B = \frac{T_F(v_v - v_l)}{\Delta h} \left(\Delta p - \frac{2\sigma}{r_B} \right) \quad (1)$$

where T_F is the bulk temperature, T_B the vapor temperature inside the bubble, v_v/v_l the specific volume of the vapor / liquid, Δh the initial supersaturation of the liquid and r_B the radius of the growing bubble. The equation of this temperature difference shows that the supersaturation of the liquid, expressed by Δp , is a very important experimental parameter. The transient temperature field around the bubble in the liquid will be recorded with an optical interferometer (Point Diffraction Interferometer).

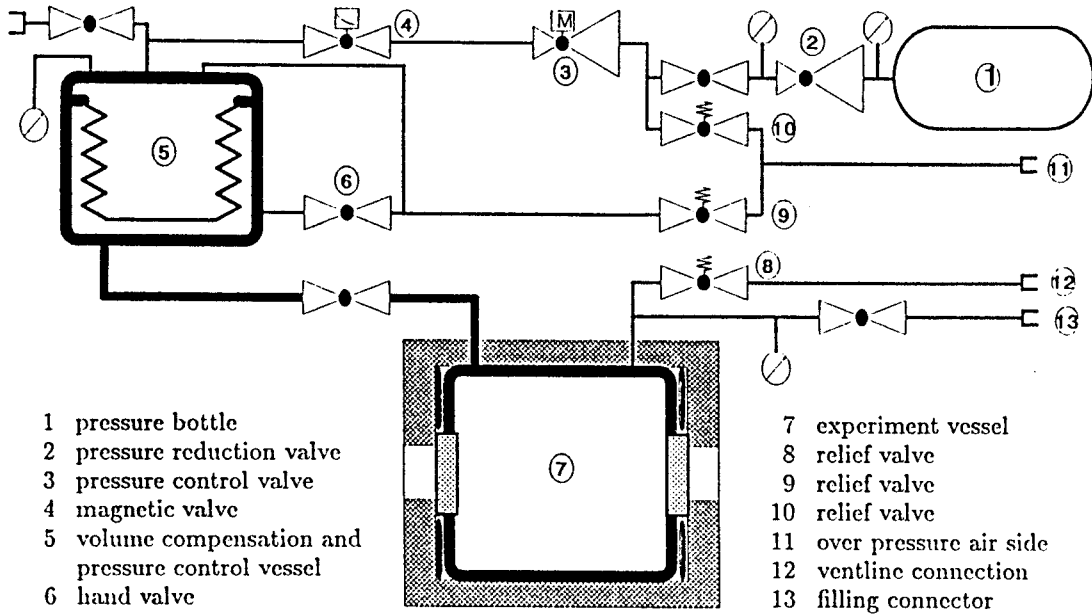

pressure control system

Figure 3: Block diagram of the pressure control unit

The corresponding net mass flux at the boundary can be calculated from the kinetic theory of evaporation and condensation as:

$$\dot{m}_{Ph} = \beta_{vc} \sqrt{\frac{k}{2\pi m^*}} \rho_{sat,v} (\sqrt{T_0} - \sqrt{T_B}) \quad (2)$$

with m^* the molecular mass, T_0 the liquid temperature at the phase boundary and T_B the temperature inside the bubble at the interface, which is assumed to be the vapor temperature T_v . The evaporation-condensation coefficient β_{vc} should be unity, according to the theoretical considerations of eq. 2. However, experimental results have been reported by various authors in the range between 0.0035 and 0.35

The reasons for such a wide range of values are not yet clear. A possibility under consideration is that the coefficient is influenced by gaseous contaminants of the liquid, and that experimental conditions are not well defined. The experiments

will thus be conducted with pure liquid and with varying amounts of dissolved gas in an overall isothermal liquid, providing the well defined conditions necessary to determine this coefficient.

Bubble Collapse

The third phase is the decrease of the bubble volume caused by increasing the system pressure. In this case the bubble follows the reverse way described for the bubble growth. The corresponding condensation coefficient will be determined, and the temperature field in the liquid is to be observed by means of optical interferometry.

3 Description of the Experimental Set-up

An experiment set-up was built for the laboratory testing and the parabolic flight experiments, incorporating the following main features of the BDPU test container: temperature control, active pressure control, compensation of the volume change produced by the growing bubble, a spot heater in the liquid, sensors for measurement of temperature, and pressure and an optical observation path.

The main components of the set-up are the experimental cell itself and a connected volume for compensation and pressure control containing a metal bellows. The metal bellows separates the fluid volume from an air volume whose pressure can be controlled by means of a pressure control valve. It is thus possible to control the fluid pressure by the air pressure acting on the metal bellows and to compensate for the volume change due to the growing bubble. This provides a close approximation to the vapor bubble growth in an isobaric fluid. A schematic drawing of the complete pressure control system is shown in Fig. 3.

The complete experiment is computer controlled and the data are recorded by the same computer. The most important data are fluid pressure, air pressure, fluid temperatures, cell temperatures, power input to the spot heater, the temperature of the spot heater, acceleration values and house keeping data.

The bubbles in the experiment cell are observed with a video camera and the pictures are stored with a tape recorder. An optical interferometer will be adapted in the future.

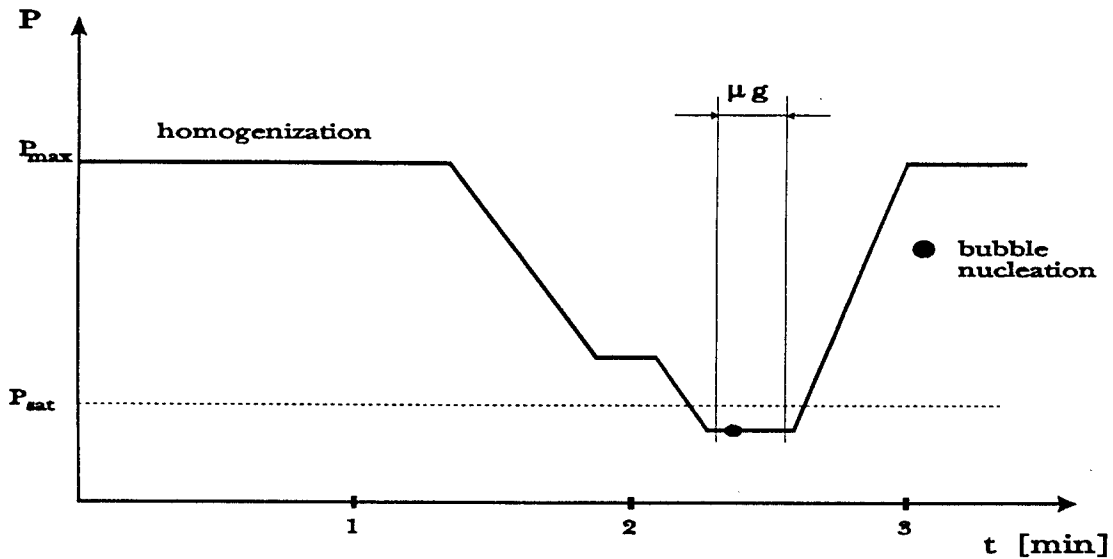

Figure 4: Pressure time diagram of one experiment run

4 Experiment Program

Experiments were conducted during two parabolic flight campaigns of the ESA aboard a Caravelle. Each parabola had an average μg time of about 20 s. Vapor bubbles are very sensitive to disturbances of the microgravity level and it could not be guaranteed that the bubbles would remain at the nucleation site for 20 s. During the second flight campaign in December a type of free floating platform of ESA / ESTEC with the experiment mounted on it was used, to improve the gravity level for the experiment.

R113 was used for the first experiments in September 91 while R11 was used as the experiment fluid in December 91. The advantage of R11 is the somewhat higher vapor pressure compared to R113. The vapor pressure of R11 at ambient temperature is $p_{sat} = 0.9890 \text{ bar}$ and for R113 $p_{sat} = 0.3625 \text{ bar}$. Therefore it is more convenient to work with R11 if no vacuum operation is possible.

A typical pressure time-diagram for one experiment run is shown in Fig 4.

The variable parameters of the experiment are the gradients of the pressure ramps, the end pressures of the pressure ramps and the temperatures. The maximum pressure for fluid homogenization was maintained at 7 bar. A stirrer was activated during the homogenization of the fluid.

5 Results of the Experiments

Feasibility of the Process

The principle process worked well. The pressure control system with the metal bellows provided a precise fluid pressure control and compensation for the growing bubble volume. Vapor bubbles were initiated with the spot heater which consisted of a thermistor. The overall feasibility for the planned Spacelab experiment was demonstrated.

Technological Results

The following results are important for the development and the design of the BDPU test container for the described experiment.

- It is difficult to reach a significant supersaturated fluid state. Vapor bubbles sometimes nucleated on the walls of the test cell. Therefore it is important that the walls of the BDPU test container are coated in such a way to achieve good wetting conditions. In addition, edges and corners should be avoided as far as possible.
- The temperature of the cell walls should be decreased before the onset of the pressure reduction process in order to avoid nucleation at the cell walls.
- The pressure control must be precise to control the nucleation and the growth of vapor bubbles in a desirable manner.
- The spot heater and the measurement thermistors should be coated to achieve non wetting conditions. This has the advantage that the vapor bubbles will surround the spot heater and the measurement thermistors.

Scientific Results

Bubble nucleation could be observed under microgravity conditions. The bubble nucleation is a very rapid process as shown by the picture series in Fig. 5. The time difference between the individual frames is 80 ms. It was not possible to observe the process of nucleation in this way during each parabola. The vapor bubbles sometimes disappeared from the field of view very rapidly, due to disturbances in the μg level.

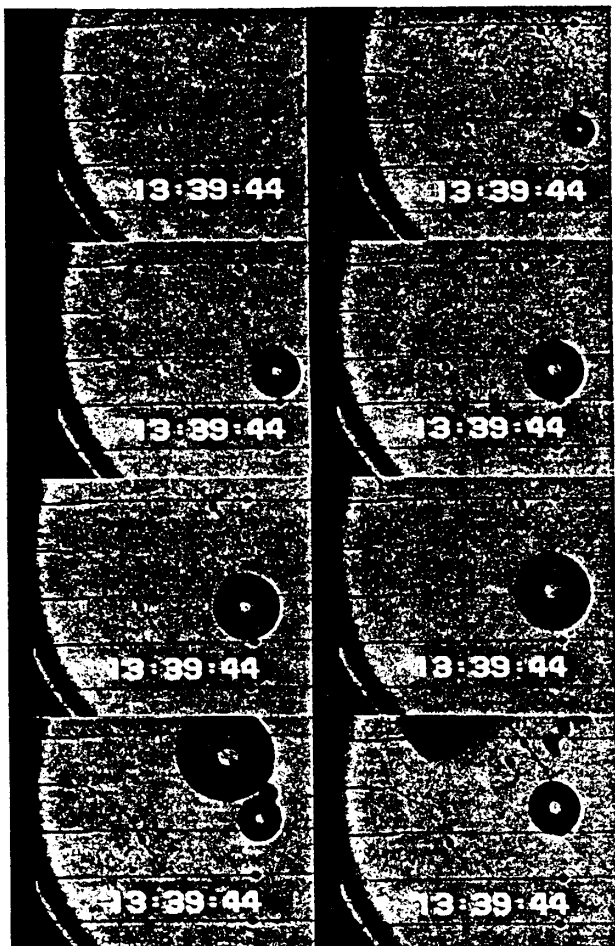
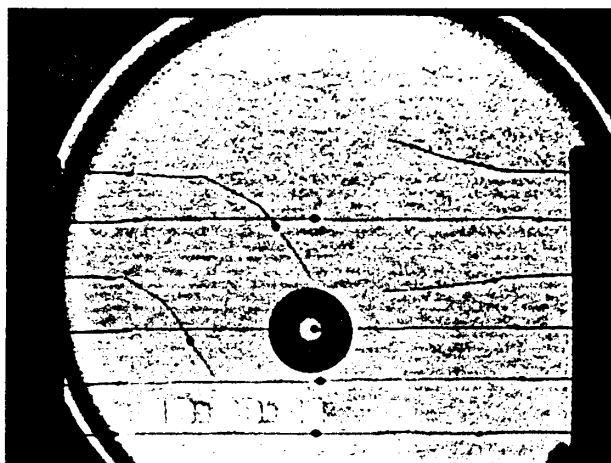

Figure 5: Nucleation of a vapor bubble in R113

Rather large vapor bubbles are generated under μg conditions relative to earth conditions. This is demonstrated in Fig. 6, where a μg bubble is compared with bubbles under earth gravity.

The next objective was to determine the evaporation coefficient of a growing vapor bubble in a homogeneous supersaturated liquid. This was not possible with the parabolic flight experiments conducted. As mentioned above, the bubbles remained at one location for only a short time, and then they disappeared. It was thus impossible to determine the evaporation coefficient. It was also impossible to determine the condensation coefficient during the bubble collapse. However experiments having a better μg level than in the Caravelle will allow the determination of the bubble kinetics and of the evaporation/condensation coefficient.



μg



1g

Figure 6: Bubble under reduced gravity and bubbles under earth gravity

6 Conclusions

The evaporation and condensation kinetics at the interface of a vapor bubble in a homogeneous supersaturated liquid will be studied in a planned Spacelab experiment. Initial experiments were performed during parabolic flights using a laboratory set-up.

The overall feasibility of the thermodynamic process for the planned experiment was demonstrated. Important technological results for the development of the BDPU experiment were obtained. Vapor bubbles were initiated using a thermistor. The evaporation and condensation coefficient could not be determined with parabolic flight experiments conducted to date, due to the disturbances of the vapor bubbles by the varying μg level.

The uncertainties for the planned Spacelab experiment were minimized by the parabolic flight experiments, and serve to optimize the scientific returns from the spacelab experiment.

Acknowledgement

The ground support program for this project is founded by the German Space Agency DARA. The flight program is founded by the European Space Agency (ESA).

References

- [1] Gerum E. *Metastabile Zustände von Flüssigkeiten*, Promotion TU München, 1977;
- [2] Gerum E.; Straub J.; *Superheating in Nucleate Boiling Calculated by Heterogeneous Nucleation Theory*, Int. J. Heat and Mass Transfer, Vol. 22 (1977), pp. 517 - 524;
- [3] Thormählen I.; *Grenze der Überhitzbarkeit von Flüssigkeiten - Keimbildung und Keimaktivierung*; Promotion TU München, 1985; veröffentlicht in Fortschritt - Berichte, VDI, Reihe 3 Nr. 104 (1985);
- [4] Wildgen A.; Straub J.; *The Boiling Mechanism in Superheated Free Jets*; Int. J. Multiphase Flow, Vol. 15 (1989), pp. 193 - 207;
- [5] Straub J.; Wildgen A.; *Onset of Boiling in a Metastable Free - Jet*; Proc. of Int. Conf. on Mechanics of Two Phase Flows (1987), Taipei, Taiwan;
- [6] Straub J.; Zell M.; Vogel B.; *Pool Boiling in Reduced Gravity Field*; Proc. of 9'th Int. Heat Transfer Conf., (1990) Jerusalem, Israel;
- [7] Zell M.; Straub J.; Vogel B. *Pool Boiling under Microgravity*; J. PhysicoChemical Hydrodynamics, 11 (1989), pp. 813 - 823;