

Chapter 16

Advanced Optical Instrumentation

F. MAYINGER

16.1 Introduction

Optical measurement techniques have the advantage not to influence the process examined and to work inertialess, which makes it possible to investigate even ultra-fast phenomena. Photographic techniques instead of point by point measuring give information about a whole field and help better to understand physical effects, which consequently makes it easier to formulate wellposed correlations.

Interferometric methods (Hauf and Grigull (1970)) have been used for many years in heat and mass transfer. In 1949 Gabor (1949) invented a new optical recording technique, which is called holography. This new recording technique combined with the interferometry - then called holographic interferometry - has many advantages, also for use in two-phase flow. It allows for example to measure the temperature distribution at the interface around a growing or condensing vapour bubble.

High speed cinematography is used since several years also in two-phase flow and in the last years some progress was made with respect to ultra-short exposure times and to the arrangement of the optical system. Exposure times of 10^{-8} s with a temporal distance of 10^{-6} s are possible today.

The X-ray technique gives information about density distribution also in fast changing fluiddynamic systems. The flash frequency can reach 10 kHz, however, the electronic processing of the X-ray picture is still rather slow with 500/1000 Hz. Luminescence methods together with a stochastic analysis using cross- and auto-correlation, can be of help for determining velocities in two-phase mixtures under certain conditions.

16.2 Holographic Interferometry

The general theory of holography is so comprehensive, that for a detailed description one must refer to the literature by Kiemle and Ross (1969), Smith (1969), Caulfield and Sun Lu (1970) and Collier et al (1971). A simple and most commonly used arrangement for holographic interferometry is shown in Figure 16.1. A laser serves as the light source. By means of a beam splitter

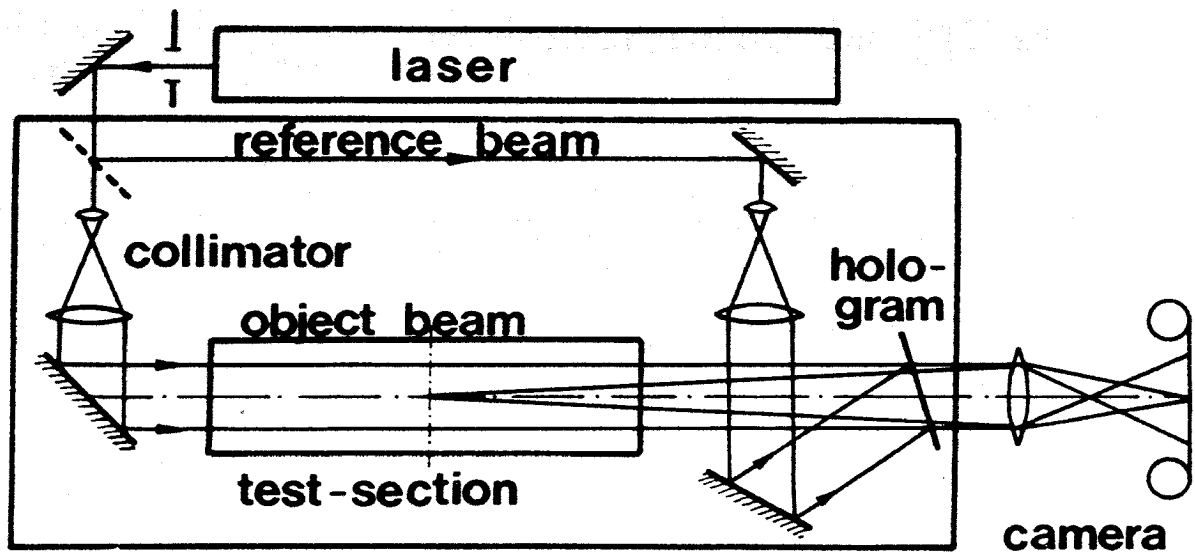

Figure 16.1: Holographic arrangement for the examination of transparent media.

the laser beam is divided into an object and reference beam. Both beams are then expanded to parallel waves by a telescope, which consists of a microscope objective and a collimating lens. The object wave passes through the test section in which the temperature or the concentration field is to be examined, whereas the reference wave directly falls onto the photographic plate - called hologram - where from the picture later on can be registered by a camera.

In a first exposure the wave passing through the test section with constant temperature distribution is recorded. This wave may, however, already be distorted because of imperfections in the windows of the test-chamber or by distortions caused by pressure and liquid or gas flow. After recording of the comparison beam the phenomena to be investigated is started. For example the temperature field is established by heating the walls of a tube. Now the incoming wave receives a continuous additional phase shift due to the temperature changes. This resulting wave front, called the measuring beam, is recorded on the same plate. After processing the hologram is repositioned and illuminated by the reference beam, as shown in Figure 16.2.

Now both object waves are reconstructed simultaneously and will interfere. The interference picture can be observed or photographed.

An example of a hologram taken by this technique, represents Figure 16.3. There the temperature distribution round a bubble growing at a heated wire of 0.4 mm diameter is shown. The bubble grows into the drift flux volume of a proceeding bubble, which left the wire a few milli-seconds ago.

By reconstructing a hologram not only a virtual but also a real image can be obtained. This can be achieved when a parallel reference beam is used and the hologram is reconstructed with the conjugate reference wave. This can be done by inverting the

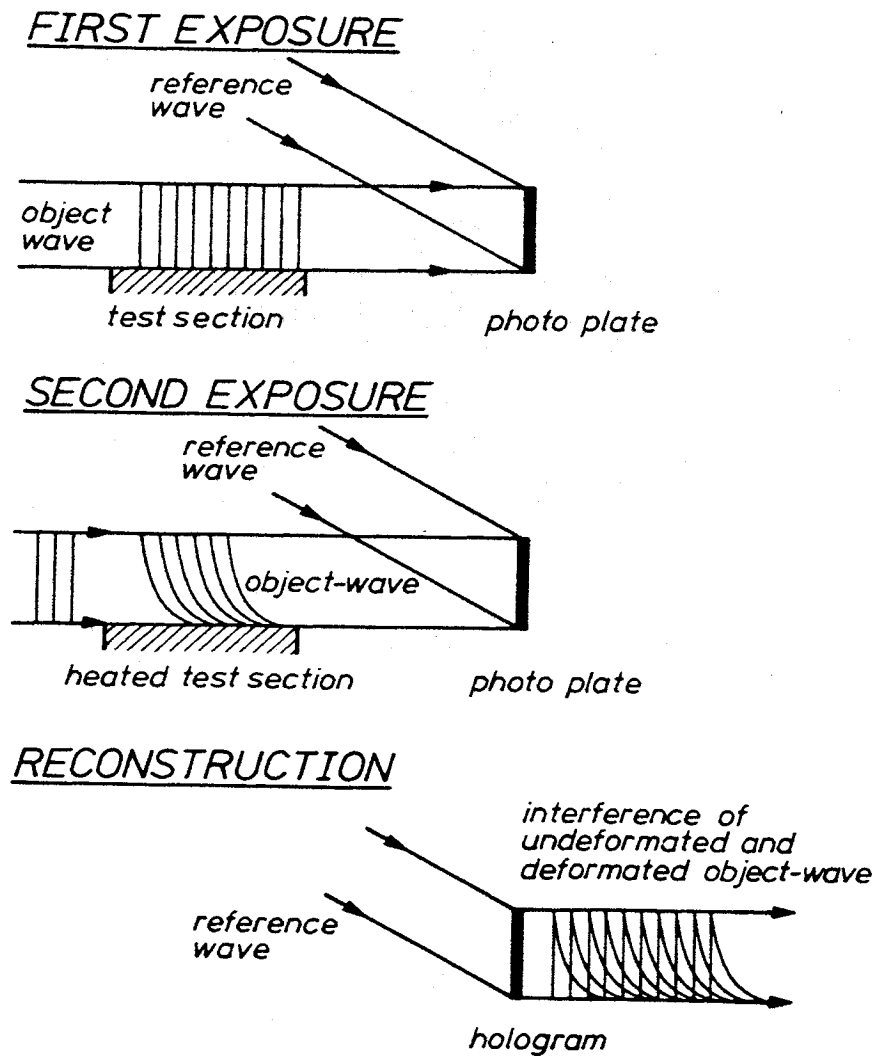

Figure 16.2: Double exposure technique.

direction of the reference wave or by simply turning the hologram itself around, as shown in Figure 16.4. The corresponding beams of the two waves recorded, then form a real image of the interference pattern and intersect in the focusing plane. In this position the recording medium (e.g. a sheet of film) is placed. No additional lenses which might distort the image are necessary. The real image can also be easily examined by a microscope and thus very narrowly spaced fringes can be studied more easily than by conventional methods, which is of great benefit in nucleate boiling research.

With the technique described so far the investigated process cannot be continuously observed. This disadvantage can be overcome if the real time method is used as illustrated in Figure 16.5.

After the first exposure, by which the comparison wave is recorded, the hologram is developed and fixed remaining at its place or repositioned accurately. The comparison wave is reconstructed continuously by illuminating the hologram with the reference wave. This reconstructed wave can now be superimposed onto the momentary object wave. If the object wave is not changed



Figure 16.3: Temperature distribution round a "secondary bubble". Water, $p = 0.3$ bar, $\dot{q} = 30$ W/cm², subcooling = 2K

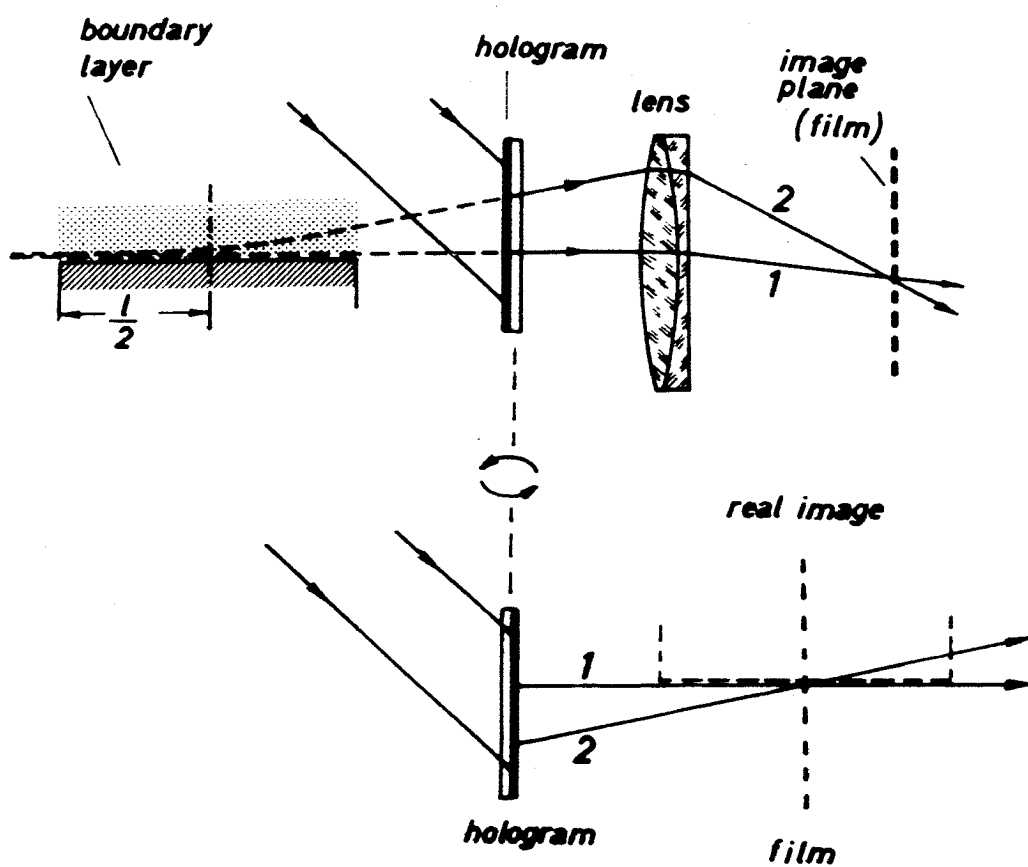

Figure 16.4: Arrangement for taking pictures of the virtual (above) and real image (below)

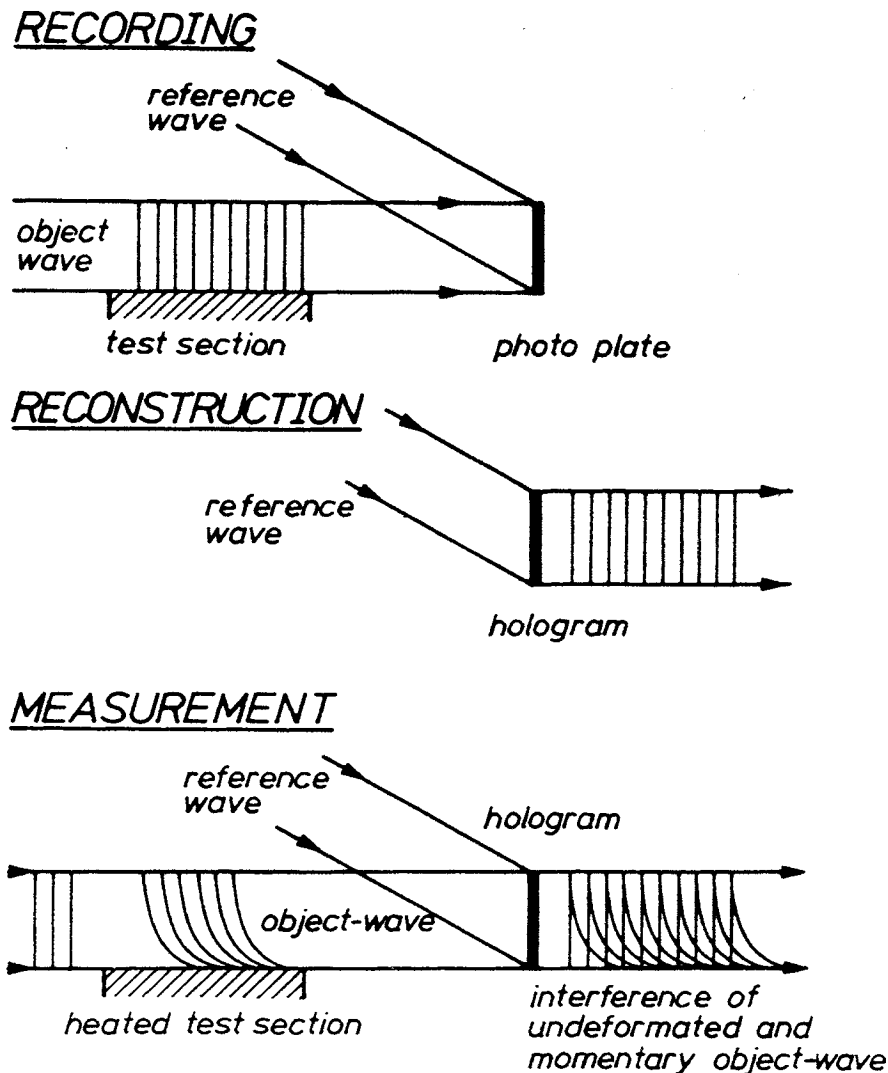

Figure 16.5: Principle of the real-time-method.

and the hologram precisely repositioned, no interference fringes will be seen at first.

Now the heat or mass transfer process, which is to be examined, can be started. The wave receives now an additional phase shift passing through the newly imposed temperature field and behind the hologram both waves interfere with each other and the changes of the interference pattern can be continuously observed or photographed on still or moving film (Mayinger and Panknin (1974)).

The evaluation of a holographic interferogram is very similar to the evaluation of interference patterns recorded in a Mach-Zehnder interferometer (Hauf and Grigull (1970)). Therefore only the basic equations will be given. As illustrated in Figure 16.6, the changes in optical path length between the two exposures can be expressed in multiples S of a wave length λ . If the length l of the test section and the refractive index of the undistorted system n_0 and of the distorted one n is known.

With the molar refractivity N and the molar mass M and by

IDEAL INTERFEROMETRY

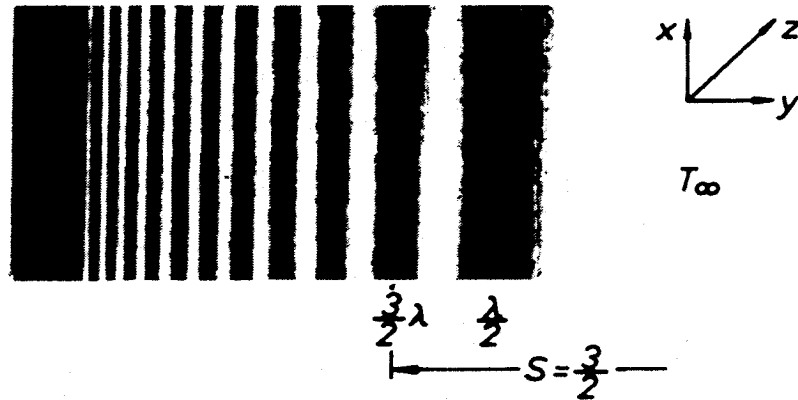

$$S \cdot \lambda = \int_0^S (n - n_\infty) dz$$

ASSUMPTIONS

- Reference - condition
 $n_\infty = \text{const.} \neq f(x, y, z)$
- Measuring condition
Two - dimensional field of refraction index
 $n = n(x, y)$
- Light beam runs straight in z-direction

$$S(x, y) \cdot \lambda = l \cdot [n(x, y) - n_\infty] = \Delta n(x, y) \cdot l$$

Figure 16.6: Ideal interferometry.

using the Lorentz-Lorenz-formula for gases, the temperature field can be evaluated by the Gladstone-Dale-equation as shown in Figure 16.7. For liquids the integration is not so easy if the refractive index is a strong function of the temperature. However, for small temperature differences, as usually present in interferometric measurements, the first derivative of the refractive index with respect to time, can be assumed to be constant. Then the temperature field also can be evaluated easily as shown on the right side of Figure 16.7.

For many technical applications the local heat transfer coefficients are of special interest. In this case the temperature gradient at the wall is determined by the holographic interferometry and, assuming a laminar boundary layer next to the wall, the heat transfer coefficient can be obtained as demonstrated in Figure 16.8.

The evaluation of a holographic interferogram discussed up to

RELATIONS BETWEEN TEMPERATURE AND REFRACTION INDEX

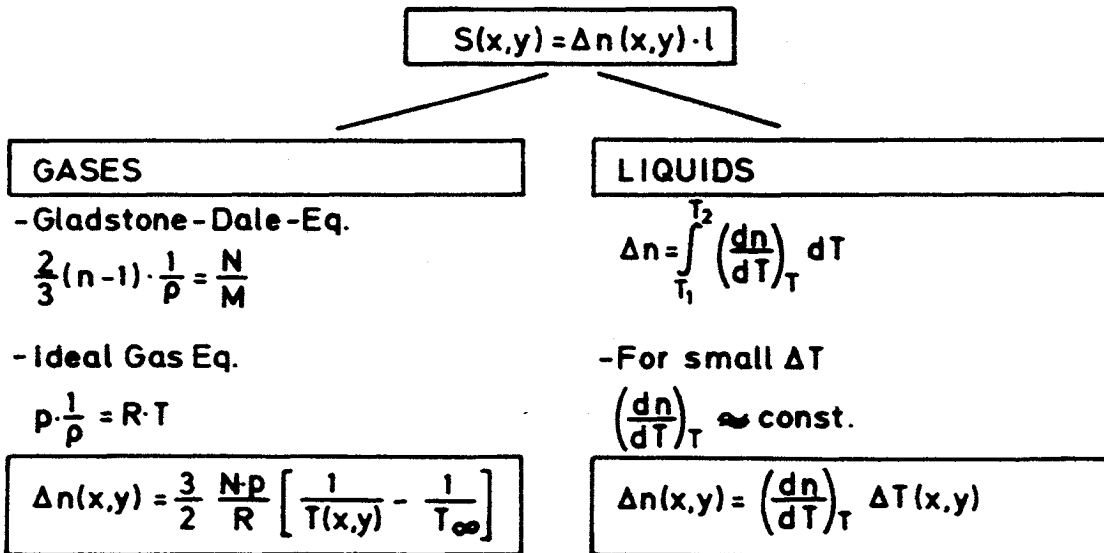

Figure 16.7: Relations between temperature and refraction index.

ENERGY BALANCE

$$q = \alpha \cdot \Delta T = -\lambda \left. \frac{dT}{dy} \right|_{\text{wall}}$$

$$\alpha = \frac{\lambda \cdot \left. \frac{dT}{dy} \right|_{\text{wall}}}{\Delta T}$$

$$Nu = \frac{\alpha \cdot L}{\lambda} = \frac{\left. \frac{dT}{dy} \right|_{\text{wall}} \cdot L}{\Delta T}$$

Figure 16.8: Energy balance.

now was for ideal conditions with a truly two-dimensional field of the refractive index - i.e. constant value of n along the path of a beam - and no deflection of the light, travelling through the temperature field. In reality - see Figure 16.9 - the laser beam undergoes a deflection and - which is more important - in many cases the temperature field is not two-dimensional but three-dimensional, which means, that each laser beam is not travelling

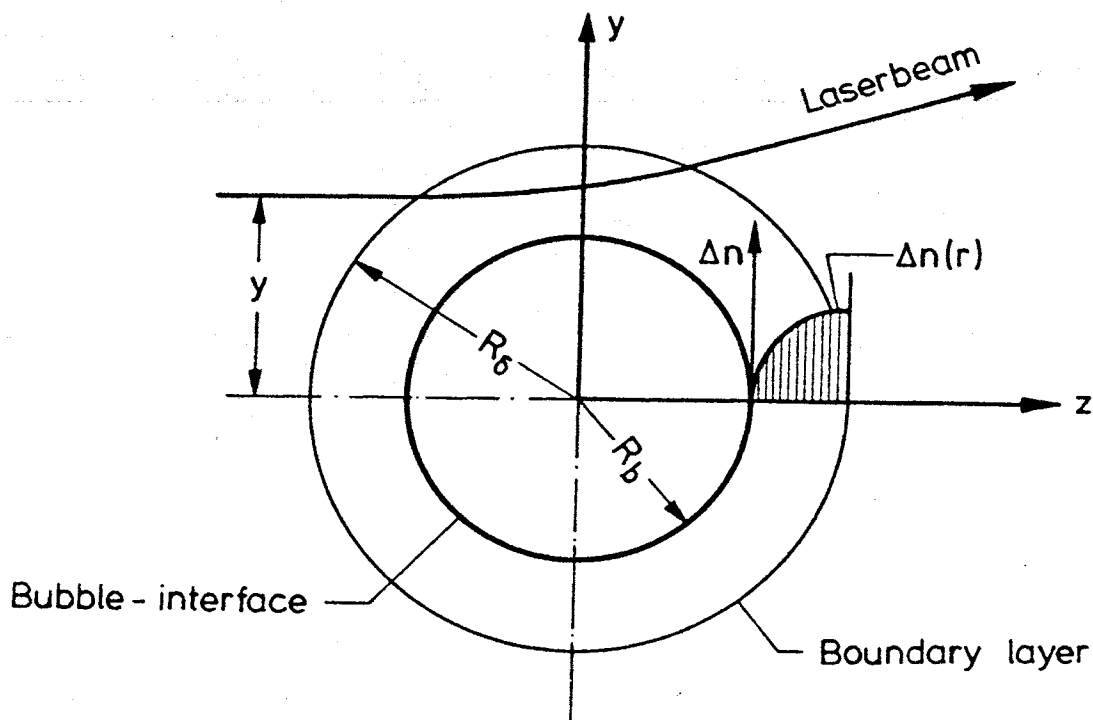

Figure 16.9: Abel-correction including light deflection.

the same distance in a certain temperature field. For spherical and cylindrical geometries Abel (Hauf and Grigull (1970)) worked out a correction method for taking in account non homogeneous temperature conditions along the travelling path of the laser beam.

If in addition the deflection has to be taken into account, the evaluation procedure becomes much more complicated. Without beam deflection, a point P in Figure 16.10 would form a picture in the position A' on the holographic plate. Due to the deflection, the laser beam leaves the boundary of the assumed temperature field at P' and forms a picture at B' . An evaluation of the interferogram needs a first estimation of the temperature field and in a complicated iterative procedure (Nordmann (1980)), the temperature distribution and the heat transfer process can be reconstructed.

In very thin boundary layers around a heated surface only a few interference fringes will occur. The evaluation then is not very precise. The situation can be improved by superimposing a finite fringe field after recording the reference hologram (see Figures 16.2 and 16.5) by inclining slightly either one of the mirrors in the holographic arrangement or the holographic plate itself, as illustrated in Figure 16.11.

An interferogram gained by this method is shown in Figure 16.12, which represents the temperature field around a condensing bubble just grown by blowing vapour out of a nozzle into a sub-cooled liquid. The finite interference fringes in the region not affected by the heat transfer around the bubble are straight lines inclined under an angle of 45° . The deviation of each interference fringe from this 45° -line is the temperature gradient in a first approximation at the phase interface.

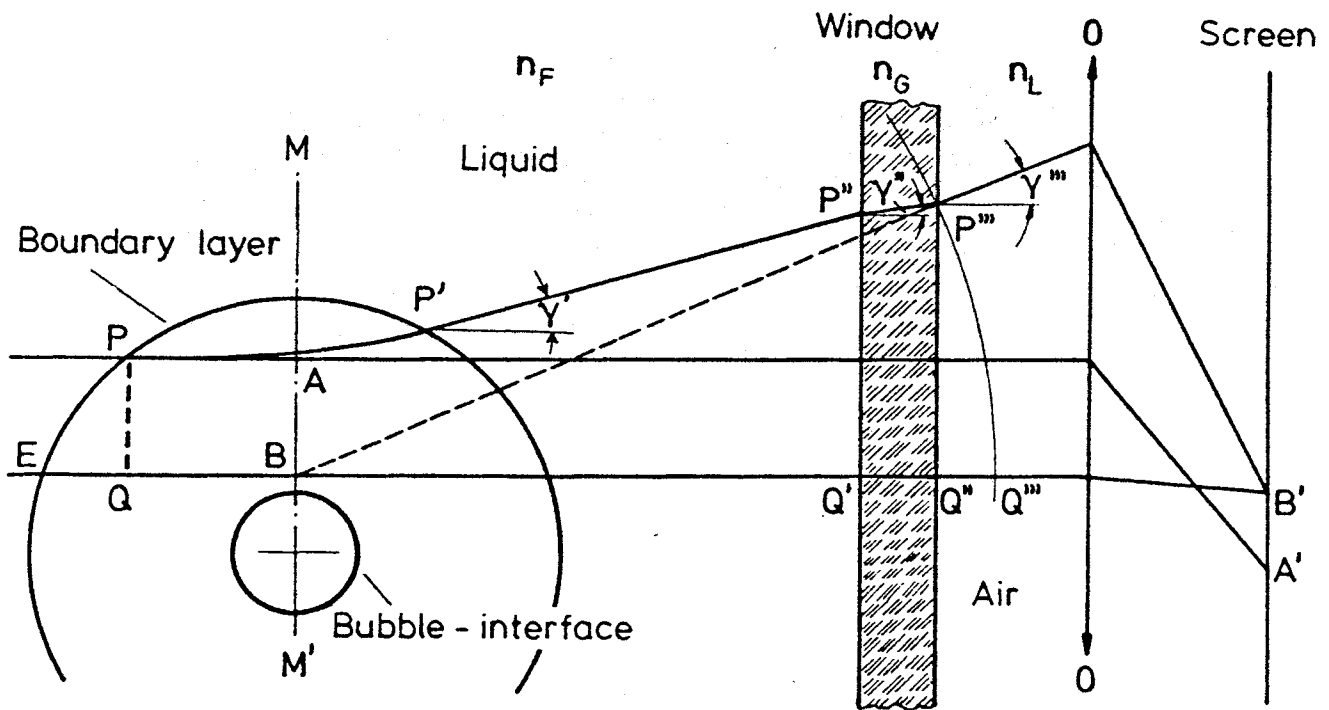

Figure 16.10: The way of the laser beam in the test chamber regarding the deflection caused by the bubble and the window.

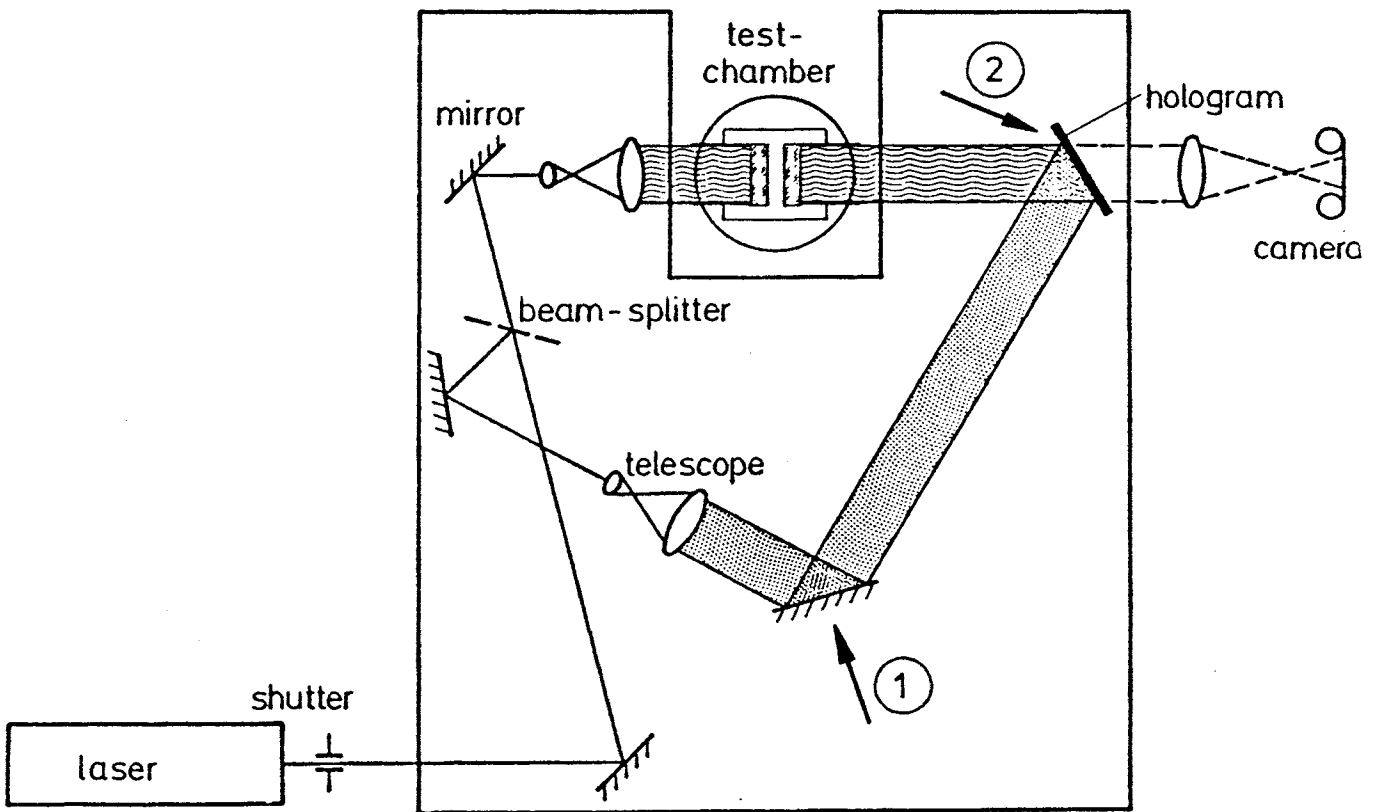

Figure 16.11: Holographic interferometer. The marked points show possibilities to adjust a fringe field.

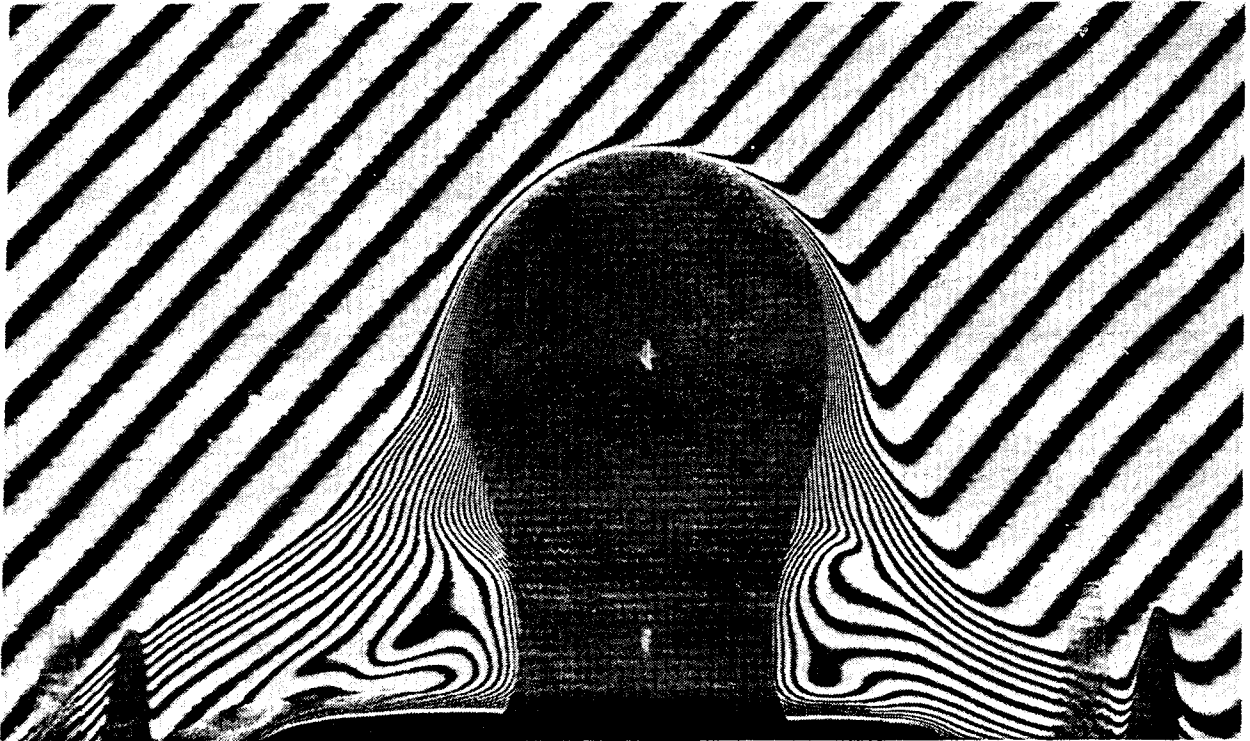

Figure 16.12: The temperature distribution around a vapour bubble growing in subcooled water; $p = 4$ bar, $\Delta T = 10$ K. To get a better sensitivity at the top of the bubble, the fringe field was adjusted in a diagonal direction.

By this method the heat transfer during the condensation of a vapour bubble in a subcooled liquid, temporarily and locally can be measured very precisely (Nordmann (1980)). Figure 16.13 gives the distribution of the Nusselt number around the circumference of a bubble condensing in a liquid which was subcooled by 16.8 K at a system pressure of 4 bar.

Thanks to the fact that this optical method works inertialess, the extremely fast condensation process can be observed accurately and interesting information can be gained of the dynamic behaviour of the bubble, and the interaction between heat transfer and inertia effects as illustrated in Figure 16.14.

16.3 High Speed Cinematography

Movy pictures with high frequency can either be taken by a rotating prisma camera or by a high frequency flash equipment, combined with a drum-camera. Those arrangements - flash equipment and camera - can also be combined.

A sketch of a rotating prisma camera is represented in Figure 16.15. The film is continuously drawn from a spool and passes the window of the lens without stopping periods, like in a usual movy camera. To get well focused and sharp pictures, the film movement has to be compensated by a rotating prisma, as demonstrated in Figure 16.16. Film movement and rotation of the prisma

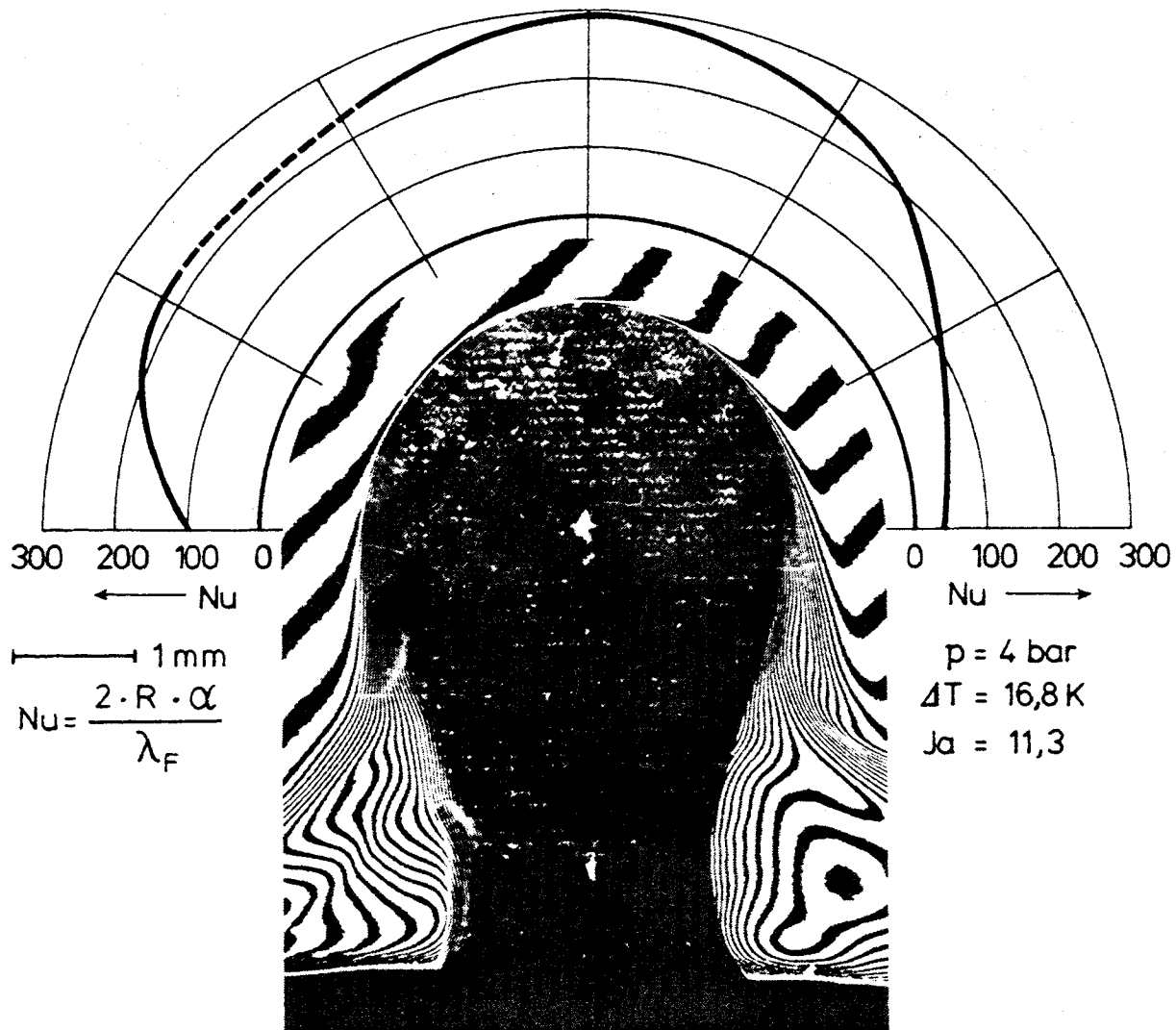

Figure 16.13: Nusselt number around the circumference of the bubble.

have to be exactly in phase.

A principle diagram for combining high speed cine-cameras - i.e. rotating prisma camera or drum camera - with the high-frequency flash equipment is shown in Figure 16.17. Commercial flash equipments have an illumination time of 10^{-6} s and make possible exposure frequencies up to 100 kHz. The manipulation of these flash units needs not only experience and experimental skillfulness usually it is very difficult too, to find a suitable triggering mechanism which makes it possible to catch exactly the fluiddynamic procedure within the extremely short exposure time available with this high speed technique. High speed cinematography is of great advantage in heat transfer measurements especially if fast changing interfacial areas and boundaries in a two-phase system have to be analysed.

An example of a high speed photograph is given in Figure 16.18, where the axial view method as proposed by Hewitt and described by Delhaye in Chapter 15 was used. Figure 16.18 shows the phase distribution of an annular two-phase flow in a tube of approximately 15 mm diameter.

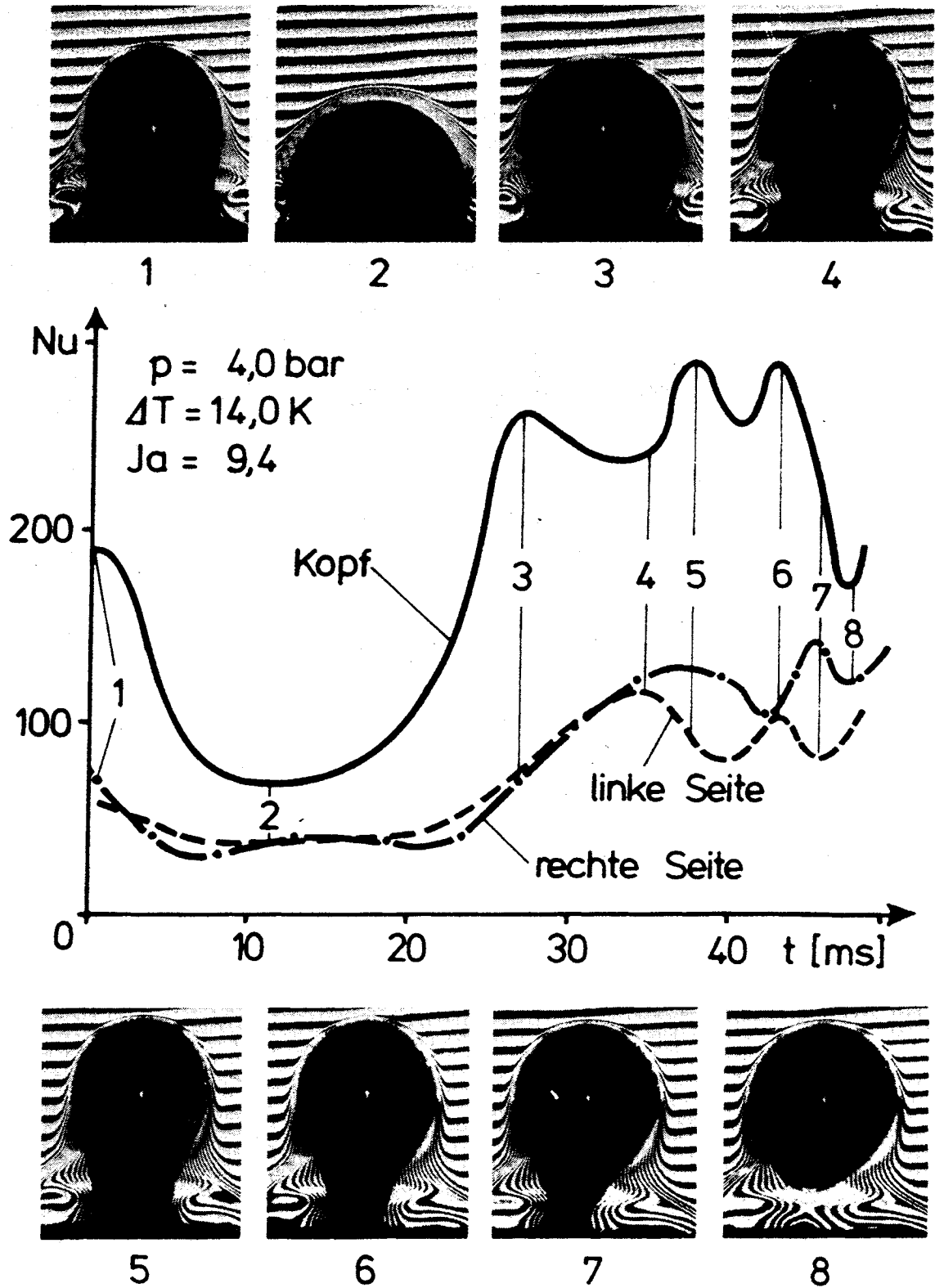

Figure 16.14: The heat transfer at the top and at the side of a growing bubble as a function of the time.

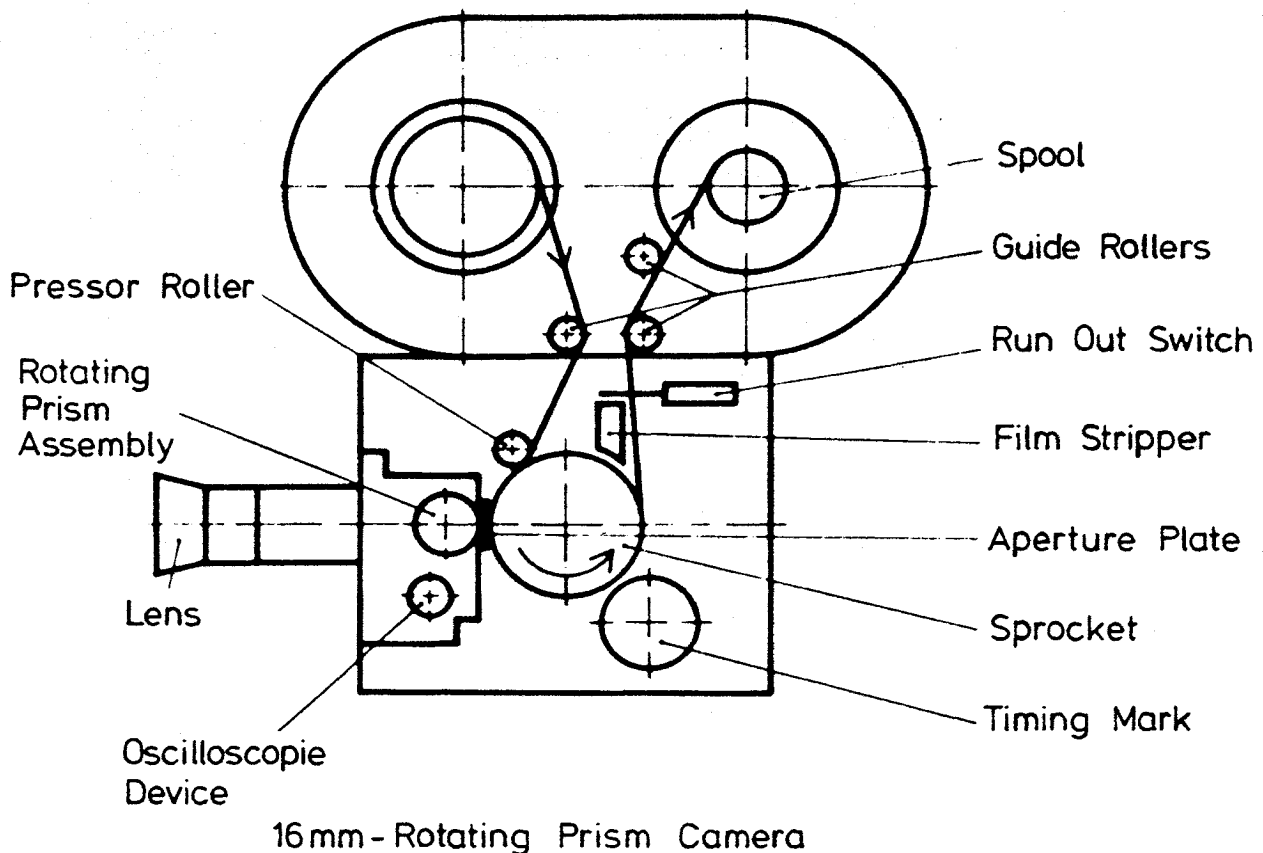

Figure 16.15: The Hitachi high speed cine camera.

For higher velocities and faster changing phenomena a method with much shorter exposure times than described up to now is needed. Many years ago, Cranz and Schardin (1929) proposed an arrangement as illustrated in Figure 16.19 which works with a number of separate flash units arranged in series and ignited in short time distances. The flash time is approximately 10^{-8} s and the time distance can be as small as a few micro seconds. With a simple camera on one and the same photographic plate a series of pictures spacially separated can be registered.

With this method flow phenomena in two-phase mixtures up to velocities of more than 100 m/s can be recorded. An example for the photographic possibilities offered by this technique is shown in Figure 16.20, where a water particle formed in the nozzle of a venturi scrubber is photographed twice by a double exposure technique within a time difference of 10^{-5} s. The velocity of the particle is approximately 80 m/s and it can be well seen how the surface of the particle is changed.

16.4 Luminescence Method and X-ray Technique

For determining the velocity also in two-phase flow the stochastic method, together with the auto- or cross-correlation is used. Signals for this technique may be temperature- or density fluctuations in the flow. If the stochastic distribution

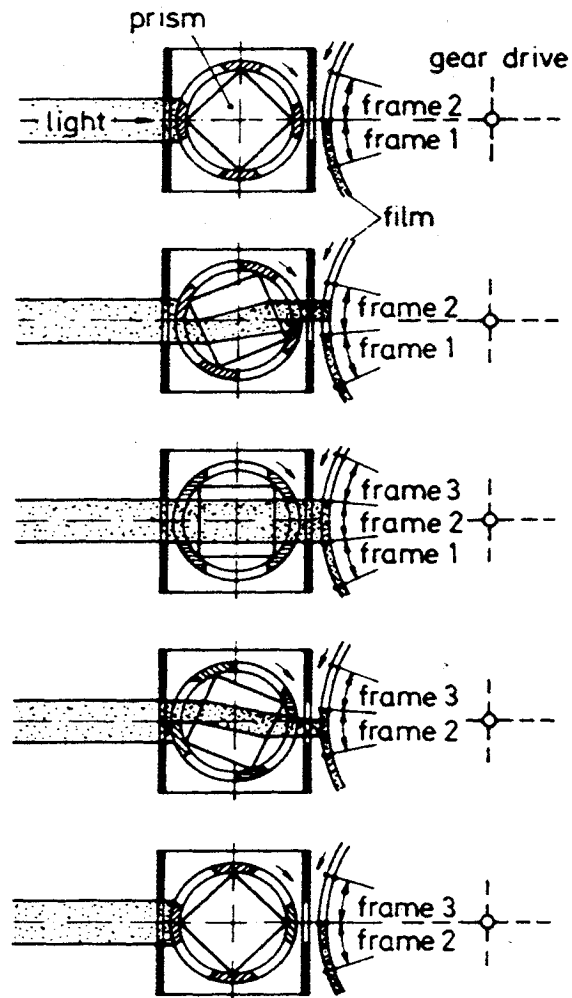

Figure 16.16: The compensation for film movement by rotating prisma.

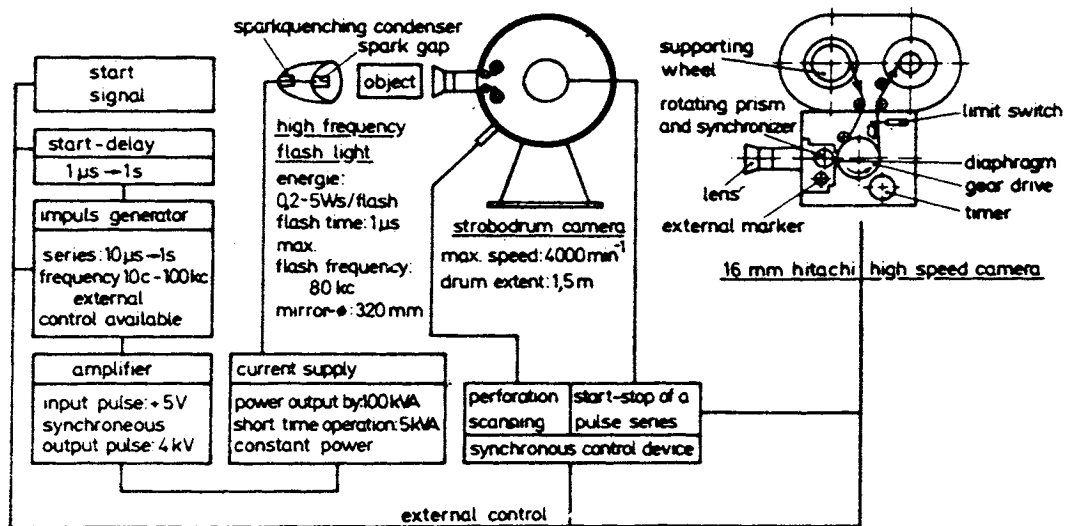

Figure 16.17: Principle diagram of the high-frequency flash equipment.

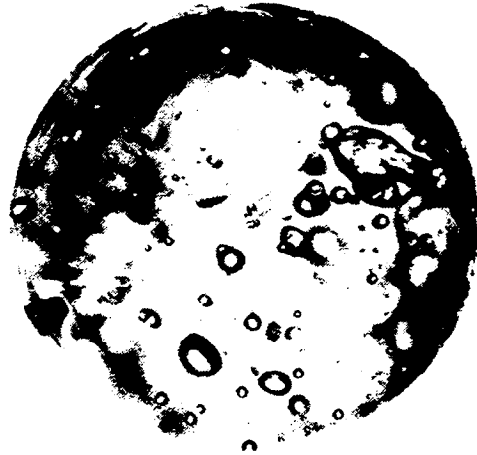

Figure 16.18: Droplets photographed by the axial view method comparison of axial and radial view.

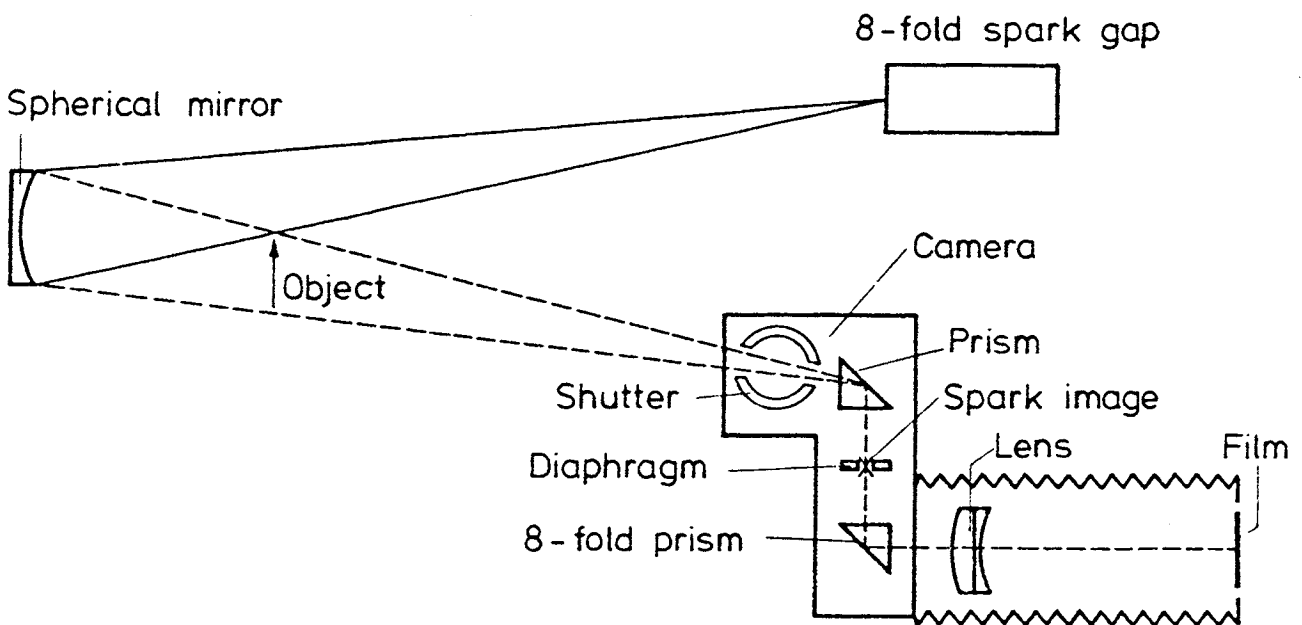

Figure 16.19: Cranz-Schardin-Multiple spark camera.



Figure 16.20: Water particle in venture scrubber, double exposure ($\Delta\tau = 10^{-5}$ s)

of these fluctuations at the second sensor is not similar to the situation at the first sensor, an evaluation is not possible or at least very erroneous. A simple puls method as illustrated in Figure 16.21 using the luminescence of certain liquids or crystals has a great advantage, because it offers a clear and well defined signal and it can be even used without the stochastic procedure. The luminescence is produced by a short ultra violet light flash through a window into the flow, which then lasts for a few seconds. In a second window, positioned in a certain distance from the first one, it then can be observed how long it takes until the luminescing fluid passes. From the distance and the delay-time the velocity can be deduced.

Besides the γ attenuation-method also the X-ray flash technique can be used for measuring void distribution and flow pattern in a gas liquid mixture. An arrangement of an X-ray flash unit is illustrated in Figure 16.22. While the X-ray flash unit

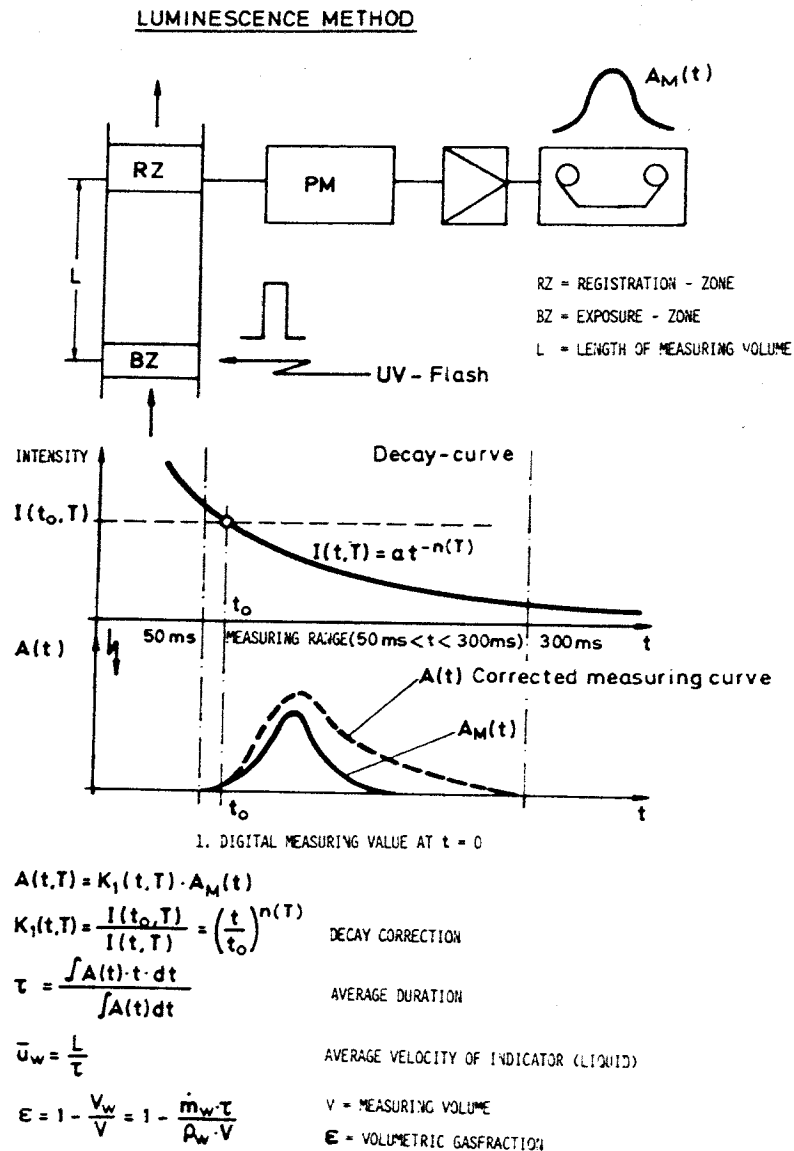

Figure 16.21: Luminescence method.

itself is a rather reliable apparatus allowing flash frequencies up to 20 kHz the image transformer plays still the weakest part in this system usually only good for 500-1000 Hz. Without this image transformer an evaluation of the pictures produced by the X-ray is almost impossible for two-phase flow, because of the low contrast. The attenuation of the X-ray is similar to that of a γ -ray and the mathematical procedure is described by Delhaye in Chapter 15.

An easier evaluation of an X-ray picture is possible by a density-display system (by Herrn Haertel) which changes the different grades of darkness in the black and white picture to a coloured system. The arrangement of such a density display system is illustrated in Figure 16.23.

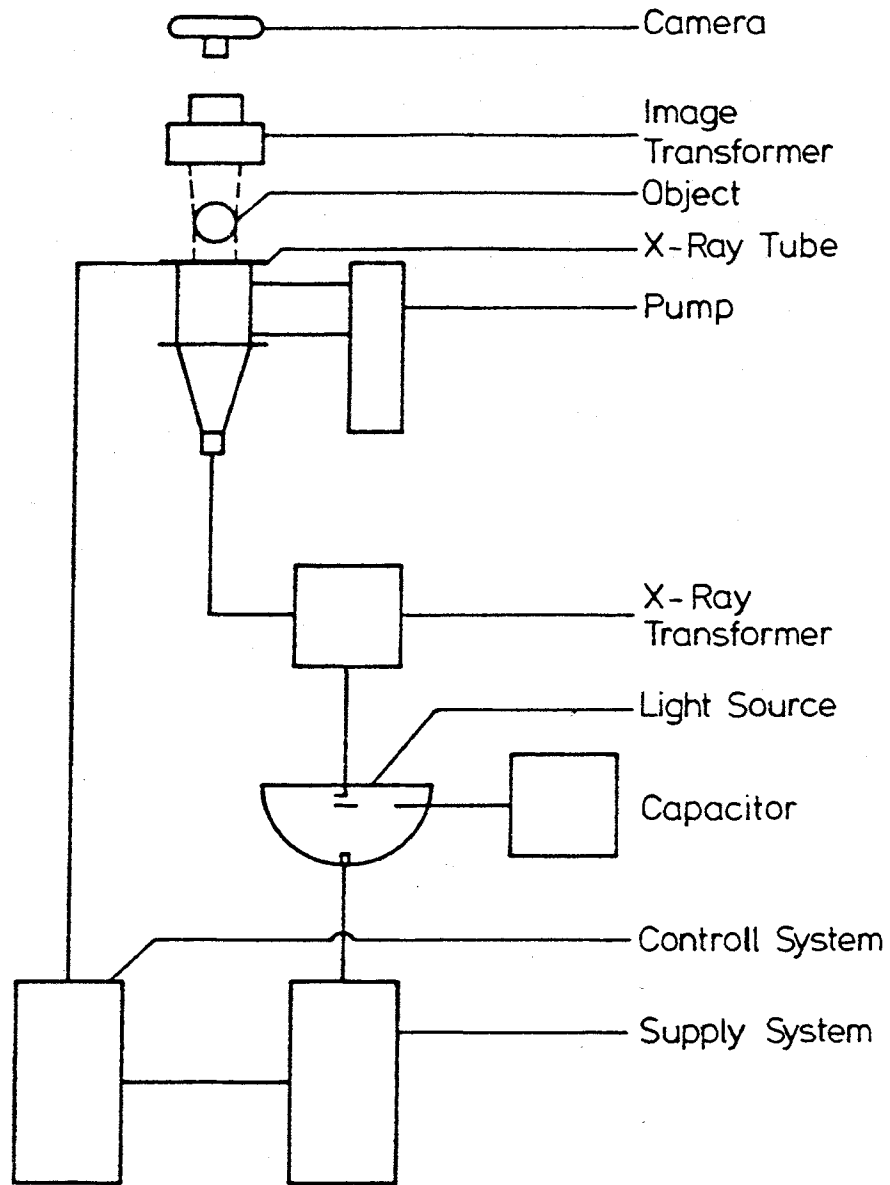

Figure 16.22: Arrangement of X-ray flash unit.

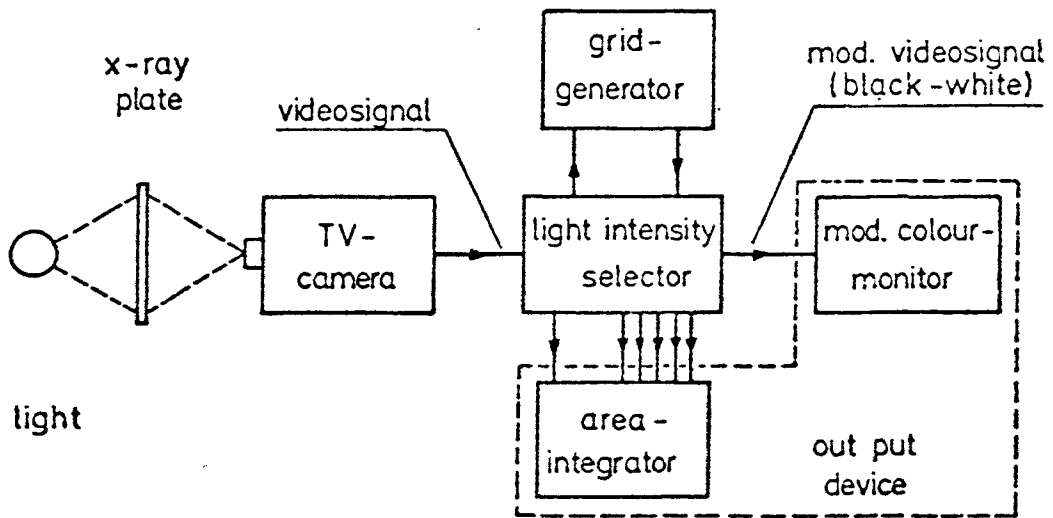

Figure 16.23: Density display system developed by Hartel.

16.5 Concluding Remarks

Optical measuring techniques have the advantage to give a visual impression of the phenomenon under research. This under certain conditions helps to get a better understanding and to formulate correlations physically in a more realistic way. However, one must not over-estimate the usefulness of these methods as long as they give only qualitative informations.

The layout and the design of an apparatus needs quantitative values of the heat- or mass transport or of the fluiddynamic conditions. Interferometric methods like the holographic interferometry offer both, a qualitative overview of the thermohydraulic system and quantitative figures of the heat and mass transport. The use of this method, together with the high speed cinematography certainly opens a lot of interesting possibilities, however, it also needs a very skillful and patient experimentalist.

References

- Caulfield, H J and Sun Lu, (1970) "The applications of holography", Wiley (Interscience), New York.
- Collier, R J, Burckhardt, C B and Lin, L H, (1971) "Optical holography", Academic Press, New York.
- Cranz, C and Schardin, H, (1929) Z. Phys. 56, 147-183.
- Gabor, D, (1948) "A new microscopic principle nature", 161, 777.
- Gabor, D, (1949) "Microscopy by reconstructed wavefronts", *Proc. Roy. Soc. A* 197, 454.
- Gabor, D, (1951) "Microscopy by reconstructed wavefronts II", *Proc. Phys. Soc. B* 64, 449.
- Haertel, persoenliche Mitteilung Institut fur Verfahrenstechnik und Dampfkesselwesen, Universitat Stuttgart.
- Hauf, W and Grigull, U, (1970) "Optical methods in heat transfer advances in heat transfer", 6, 133.
- Kiemle, H and Roess, D, (1969) "Einfuehrung in die Technik der Holographie", Akademische Verlagsgesellschaft, Frankfurt/M.
- Mayinger, F and Panknin, W, (1974) "Holography in heat and mass transfer", *Heat Transfer* 1974, VI, 28-43, 5th International Heat Transfer Conference, Japan.
- Nordmann, D, (1980) "Temperatur, Druck und Waerme transport in der Umgebung kondensierender Blasen", Diss. Universitat Hannover.
- Smith, H M, (1969) "Principles of holography", Wiley (Interscience), New York.
- Varadi, G, Nabizadeh, H and Lordong, N (1977), "Entwicklung neuer Messmethoden zur Bestimmung der Phasengeschwindigkeit in einer Zweiphasenstroemung", *Kerntechn. Ges. im Dt. Atomforum e.V. Experimentiertechnik auf dem Gebiet der Thermo- und Fluidodynamik*, Teil 2.