

SOME EXPERIMENTS ON THE REGELATION OF ICE

E. Hahne and U. Grigull

Institut für Technische Thermodynamik

Technische Hochschule München/Germany

Abstract

This classical experiment with a wire cutting through a block of ice was performed with variations in wire material, wire size and effective bearing pressure. As material, copper and "Perlon" were used with diameters ranging from 0.125 to 1 mm. Pressures of 5, 8 and 10 bar were applied. In order to investigate surface effects two different metallic materials, copper, and stainless steel (V2A), of markedly different thermal conductivity were coated with silver and insulating varnish. The experimental results presented in terms of speed of the wire cutting through the ice show good agreement with results predicted by a model theory based on heat conduction.

Experimental setup

The classical experiment for the regelation- or refreezing- phenomenon is performed with a wire cutting through a block of ice and nevertheless leaving the block undivided.

It was the object of our experiments to learn about the governing mechanism of this phenomenon.

For this reason different wires were used to penetrate through a block of ice 40 cm long and 12 cm in square. A sketch of the experimental set up is given in figure 1. Three wires of different diameters were used at a time

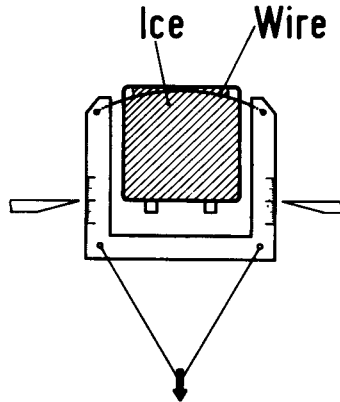

Fig.1 Experimental set up

in one run. Each wire was held in a rigid wooden frame which was loaded with such a weight that the bearing pressure was the same for each wire.

This pressure was calculated from the weight, the diameter and the bearing length of the wire. Since the experiments were performed in a room with a rather constant temperature of 22°C , heat was conducted along the wire into the ice by the so-called fin-effect. The wire length influenced by this effect could be calculated as well as measured. Since the surplus heat from the room prevented the refreezing of the water above the wire, a wedge-shaped mark showed the influenced length on either side of the block. This influenced, heated length was not considered as bearing.

The penetrating wires were always placed some distance away from the ends of the block, so that influences by edge effects or structural differences in the ice are kept small.

The descent of the wires within certain time intervals was observed from a millimeter scale on the frames and from this the penetration speed was calculated.

Preparation of ice

The first experiments had shown that the penetration speed is quite sensitive to impurities in the ice, especially to air. So it had to be a main object to produce constant quality ice. Clear transparent blocks were obtained from distilled water which had been kept boiling for at least 30 minutes in order to drive out the air. The freezing of the water took about 8 hours in a

rectangular shaped container which floated in a cold bath. One long side of the container was open and the water was stirred continuously. Several times the liquid part with the remaining impurities and reabsorbed air was exchanged for fresh treated water.

Still remaining impurities collected in the upper part, in the section which froze last.

In figure 2 two blocks of ice are shown, one with air and the other treated as described.

In the test runs the blocks were turned upside down, so that the contaminated section formed the bottom part and could not affect the experiment.

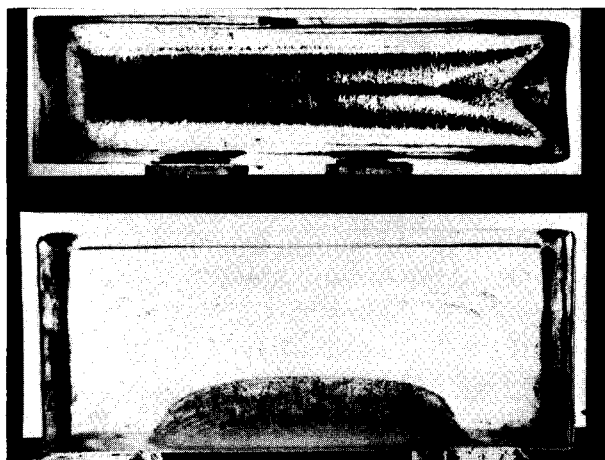

Fig.2 Ice blocks

Experiments

In the experiments different wire diameters, different bearing pressures and different materials were applied.

The materials were selected with respect to their thermal conductivity, copper, with a thermal conductivity $k = 370 \text{ W/m}\cdot\text{deg}$, spring steel with $k = 30 \text{ W/m}\cdot\text{deg}$ and Perlton with $k = 0.3 \text{ W/m}\cdot\text{deg}$ were used.

The results of the experiments are presented in figure 3. The penetration speed is given as a function of wire diameter, with the mean pressure as parameter. There is a distinct difference in the behaviour of the two materials. The Perlton string is moving considerably slower than the copper wire. For both materials an increase in diameter causes a decrease in penetration speed, while

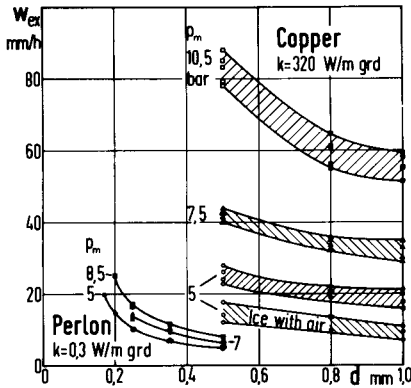

Fig.3 Penetration speed of copper and Perlon wires

an increase in pressure also increases the speed. There is a striking difference in the scatter of the results. The reproducibility of Perlon tests is much better than that of copper. Reasons for this will be discussed.

The plot also shows some results for ice with air inclusions. The penetration speed in this case is always below that for air-free ice.

In order to learn about possible surface effects [1] copper wires and spring steel wires were either silver plated or coated with insulating varnish. Again these coating materials were chosen for their great difference in thermal conductivity. The results of these tests are presented in figure 4.

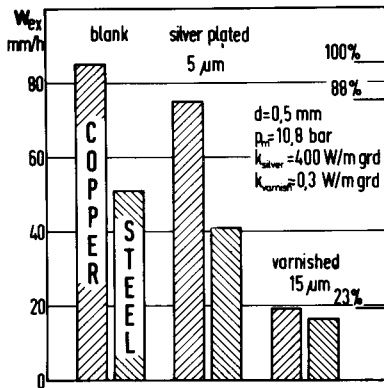

Fig.4 Penetration speed of silver-plated and varnished wires

The penetration speed is shown for blank, silver-plated and varnished wires. In all runs the diameter of the wires was constant 0.5 mm, and the applied bearing pressure 10.8 bar. The silver-plating was 10 μm thick, the varnish coating 15 μm .

The difference in speed between the two different materials is maintained even though the surfaces of the probes were the same: silver or insulating varnish.

The plot shows that silver plating causes a reduction in speed of about 12%, if the blank copper is taken as the 100% reference. The varnish layer decreases the speed by about 77%.

Observations in the experiments

Some observations made in the experiments might be worth mentioning. The scatter in the results for copper wires induced a number of variations in the performance of the experiments. It turned out that the best possible reproducibility was achieved by using the copper wires only once. Multiple use brings about uncontrollable deposits on the surface.

The main reason for the scatter of the experimental results was found in the appearance of bubbles along the wire. These bubbles were formed on the wire and were left behind in the ice while the wire moved downwards. About 15 minutes after their appearance, these bubbles vanished again in most cases. The occurrence of bubbles was always connected with a decrease in wire speed.

In figure 5 these bubbles are shown in a block of ice. The decrease in speed is also recorded in this picture. If the wire remains longer in one place, more heat is conducted from the surroundings along the wire into the ice. This means that the incisions from both sides are deeper when bubbles appear. In the picture the deeper cuts indicate this bubble appearance.

In general the largest bubbles were observed on the thickest wire of 1 mm diameter, the most frequent appearance occurred on the 0.8 mm wire. Frequently used wires showed a greater tendency for bubble creation than new ones. Only little bubble formation was observed on silver-plated and varnished wires. So far no special investigation was performed on the nature and the causes of these bubbles.

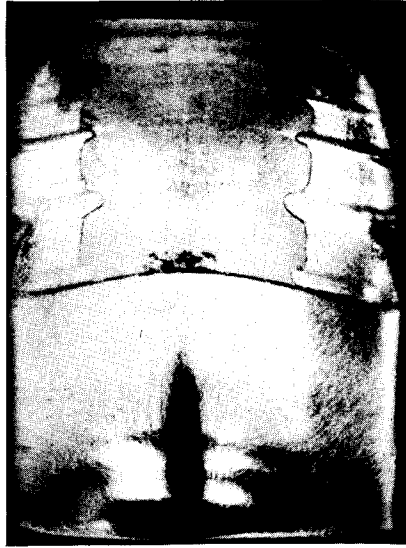

Fig.5 Bubbles on the wire

Theoretical considerations

The strong dependence of the penetration speed on the thermal conductivity of the wire led to the consideration that heat conduction is the significant parameter.

Two different models, for high and low thermal conductivity specimen were assumed and are presented in figure 6. Only steady state conditions will be considered, as far as heat conduction is concerned. In either case, the specimen is assumed to be surrounded by a very thin layer of liquid water.

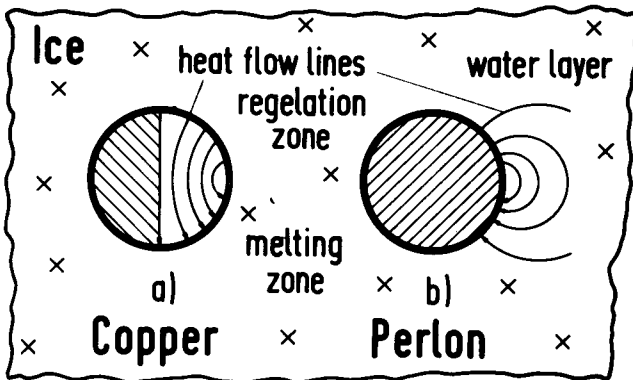

Fig.6 Heat conduction model

This originates from the melting of the ice below the wire, is pressed around the wire and freezes again above it. In freezing, the latent heat of melting is set free above the wire, while below the wire it is needed to melt the ice.

So it is assumed that heat will flow from the upper freezing section to the lower melting section. The paths which it takes depend on the thermal resistance or the thermal conductivity of the layers passed.

With copper of a high thermal conductivity and consequently a low resistance, the flow lines are assumed to go through the water layers and the wire as shown in a) of figure 6.

Perlon on the contrary has a low thermal conductivity, so the string represents a high resistance and the flow lines are assumed to go around the wire through the ice, which has a thermal conductivity greater by an order of magnitude than that of Perlon.

For these model cases, the Laplace equation was solved analytically. Using Fourier's equation and the Clausius-Clapeyron relation a heat balance was established from which the penetration speed could be determined as given in the following equations.*

For model fig.6a:

$$\underline{w}_a = \pi T (\underline{v}_s - \underline{v}_l) P / 4 \rho_I l^2 (d/\lambda_{Cu} + 2\delta/\lambda_{H_2O}) \quad (1)$$

and for model fig.6b:

$$\underline{w}_b = \pi T (\underline{v}_s - \underline{v}_l) P \lambda_I / 4d \rho_I l^2 \quad (2)$$

where \underline{w} is the penetration speed, T the melting temperature, \underline{v} the specific volume of solid (s) and liquid (l), p the bearing pressure, ρ_I the density of ice, l the latent heat of melting, d the wire diameter, δ the water layer thickness and λ the thermal conductivity of copper (Cu), water (H₂O) and ice (I).

In figure 7, comparison is presented between the theoretical and the experimental results. The ratio of the theoretical speed to the experimental speed is plotted against the bearing pressure.

Full agreement between theory and experiment would result in data on the horizontal line 1. As an explanation for the deviations it should be considered that the

*The detailed calculation procedure will be published later.

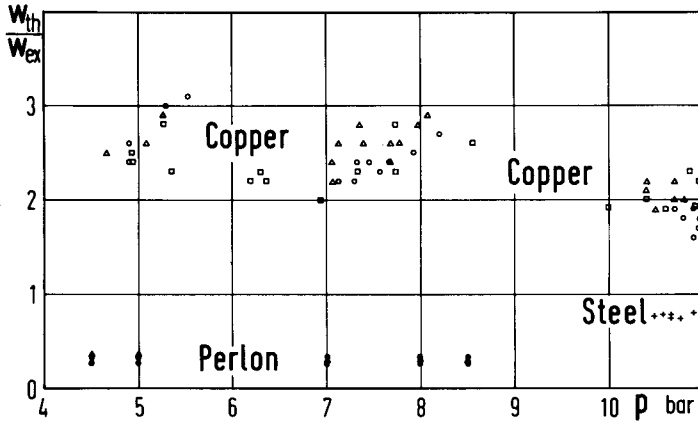

Fig.7 Comparison between theory and experiment

theoretical speed in the copper model requires an assumption for the waterlayer thickness. For the sake of simplicity a value of $1 \mu\text{m}$ was chosen. An increase to $2.3 \mu\text{m}$, however, would bring the data points well around the full agreement line.

For the Perlon model it has to be realised that the ratio of the thermal conductivities of ice and Perlon only amounts to 7 while this ratio for copper and ice is about 170.

This means that the model a) for copper seems appropriate while the model b) for Perlon needs corrections for that part of the latent heat which passes through the Perlon string. Such a correction based on the thermal conductivities and the heat path lengths brings the data also closer to the full agreement line. The correction, however, again depends on assumptions. For the spring steel data also it has to be considered that heat will flow through the wire and around it, so that none of the mentioned models applies exclusively.

The theoretical consideration of the silver-plated wires predicts a decrease in speed of about 1% due to the additional silver layer. The experiments, however, give a decrease of 12% for copper and 18% for steel. Since the heat path lines should not be changed very much by the silver layer, the model a) should still be valid and the extra decrease in speed might indicate an additional effect.

The small difference in penetration speed with the varnished wires might be explained by the drastic change,

from the model a) to the model b) heat flow pattern, where the wire material is of no influence.

Concluding it might be stated that heat conduction seems to play the dominant part in regelation.

The deviations of the silver-plated wires from theory indicate, that additional effects such as surface interactions might be present.

Acknowledgement

The authors gratefully acknowledge the assistance of R. Habeck and J. Hoiss in the execution of the experiments.

References

- /1/ Weyl, W.A., J.Coll.Sci 6, 389-405 (1951)
- /2/ Nye, J.F., Phil.Mag. Ser.8, 16, 1249-1266 (1967)
- /3/ Frank, F.C., Phil.Mag.Ser. 8, 16, 1267-1274 (1967)
- /4/ Townsend, D.W., R.P.Vickery, Phil.Mag.Ser. 8, 16 1275-1280, (1967)
- /5/ Nunn, K.R., D.M. Rowell, Phil.Mag.Ser.8, 16 1281-1283 (1967)

* After submitting this paper, the authors learned that work on regelation had been carried out by Dr.J.F.Nye, Professor F.C.Frank and others at H.H.Wills Physics Laboratory, University of Bristol.